

# 1500 Series Intelligent Electropneumatic Valve Positioner



1500 series intelligent electropneumatic valve positioner is designed for integral pneumatic control valve, particularly suitable for angle seat valves and diaphragm valves.

The product is easy to operate. It can easily be operated via the keypad.

The positioner adjusts the valve position quickly and accurately through detecting the position sensor signal.

- Electrical waterproof connectors
- LED display
- Easy to start-up

## Technical data

Material	PC、PA6-GF30、SI
Power supply	24V DC $\pm 10\%$
Set-point signal	4 – 20 mA
Input resistance for set-point signal	120 $\Omega$
Control medium	neutral gases, air DIN ISO 8573-1
Dust concentration	Class 5 (<40 $\mu\text{m}$ particle size)
Particle density	Class 5 (<10mg/m <sup>3</sup> )
Pressure condensation point	Class 3 (<-20°C)
Oil concentration	Class 5 (<25mg/m <sup>3</sup> )
Ambient temperature	0-70°C
Pneumatic connection	Plug-in hose connector G1/4(internal $\Phi 6\text{mm}$ )
Electrical connection	M12 3-pins B-coded (cable $\varnothing$ 4-6mm) M12 4-pins D-coded (cable $\varnothing$ 4-6mm)
Supply pressure	3~7 bar, specific values depending on the actuator
Air flow rate	17 l/min(input pressure of 0.6Mpa) 58 l/min(input pressure of 0.6Mpa, only single-acting)
Stroke control range	Line 5-50mm Angle 90°
Installation	As required, Preferably with actuator in upright position, Screw
Protection class	IP66
Power consumption	<5W

# Combinations

---



**Diaphragm control valve**



**Angle seat control valve**

## Structure

---

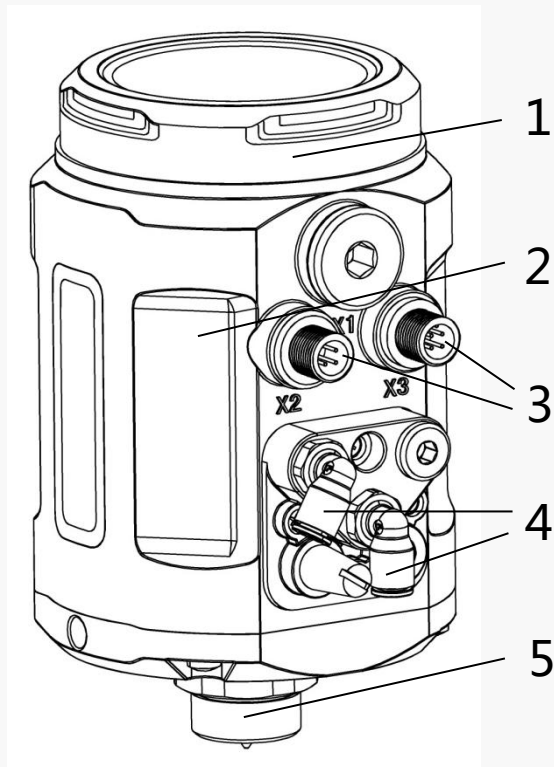

1. Protective cover
2. Main body casing
3. Electrical connection
4. Pneumatic connection
5. Actuator connection

# Dimensions

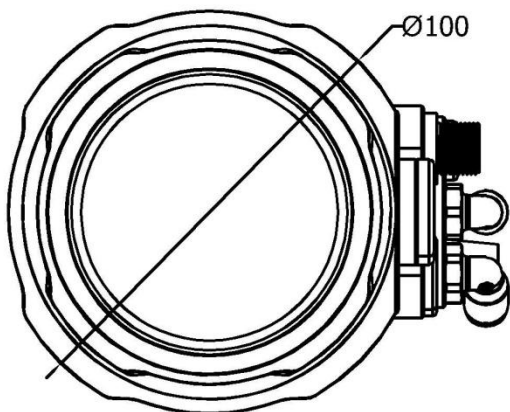
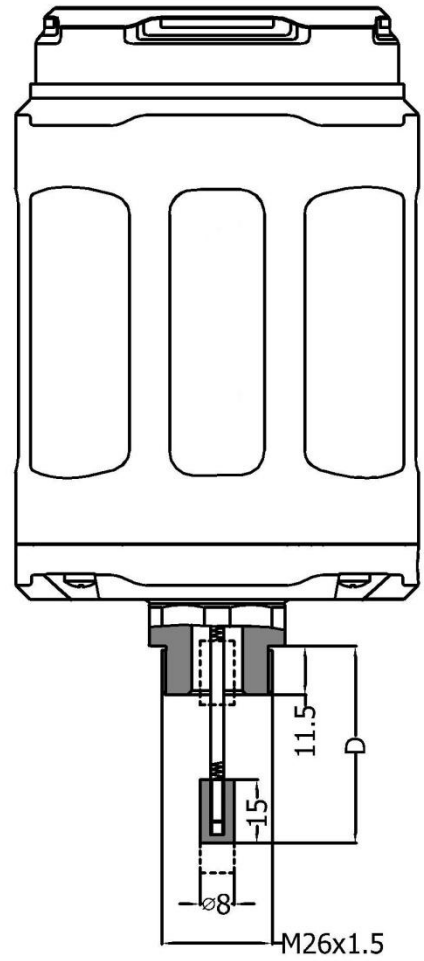
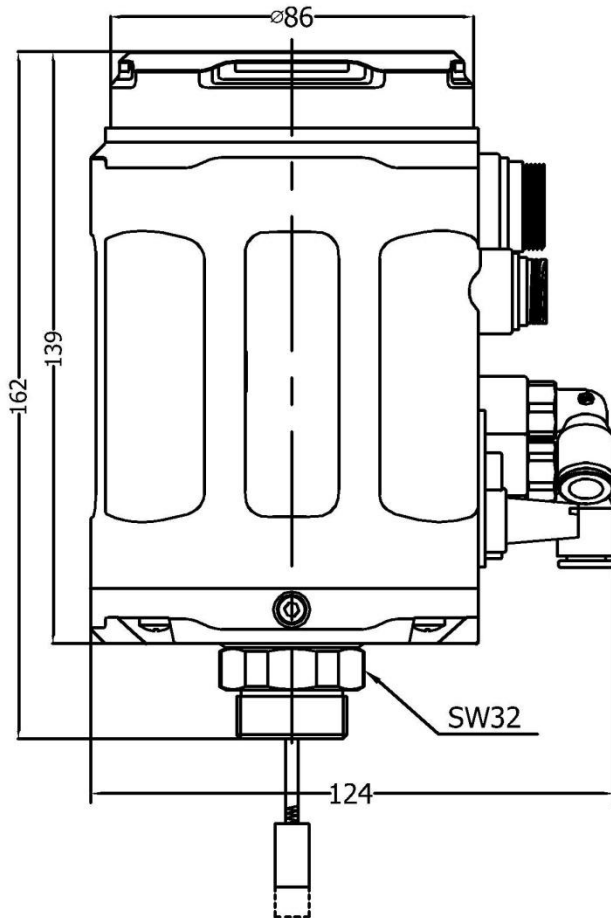

## Interface angle adjustment

The angle can be adjusted between the positioner and the valve. If need to adjust the interface angle, relaxing the hexagon screw in place A first. Then adjusting the angle clockwise or counter-clockwise in 180° range. After adjusting the angle, locking the angle by the hexagon screw.

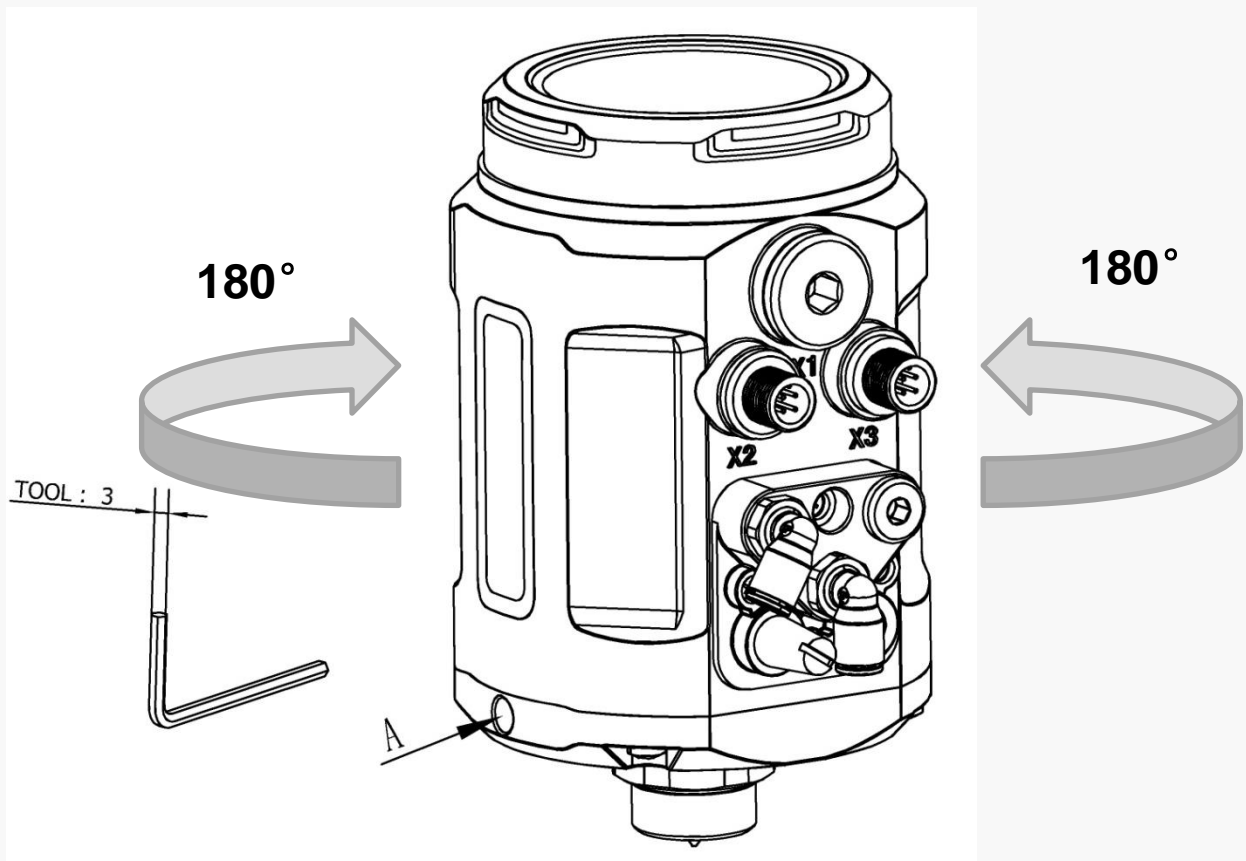

## Electrical connections

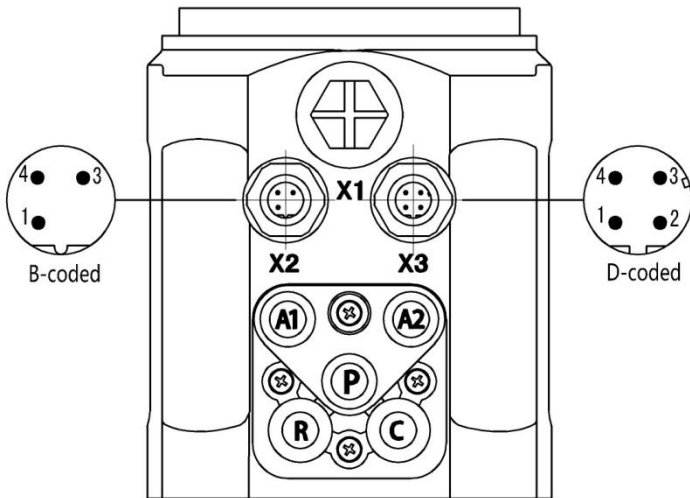

### X2(optional)

Pin	Description	Signal type
1	Analogue signal output +	4 – 20 mA
3	Analogue signal output GND	GND
4	NC	NULL

### X3

Pin	Description	Signal type
1	Power supply +	+24 V
2	Power supply GND	GND
3	Set signal input +	4 – 20 mA
4	Set signal input GND	GND

## Pneumatic connections

<b>P</b>	Air supply enter(built-in filter, filter size 5 µm)
<b>R</b>	Air exhaust
<b>C</b>	Check valve
<b>A1</b>	Pilot air outlet 1
<b>A2</b>	Pilot air outlet 2

# Product type selection

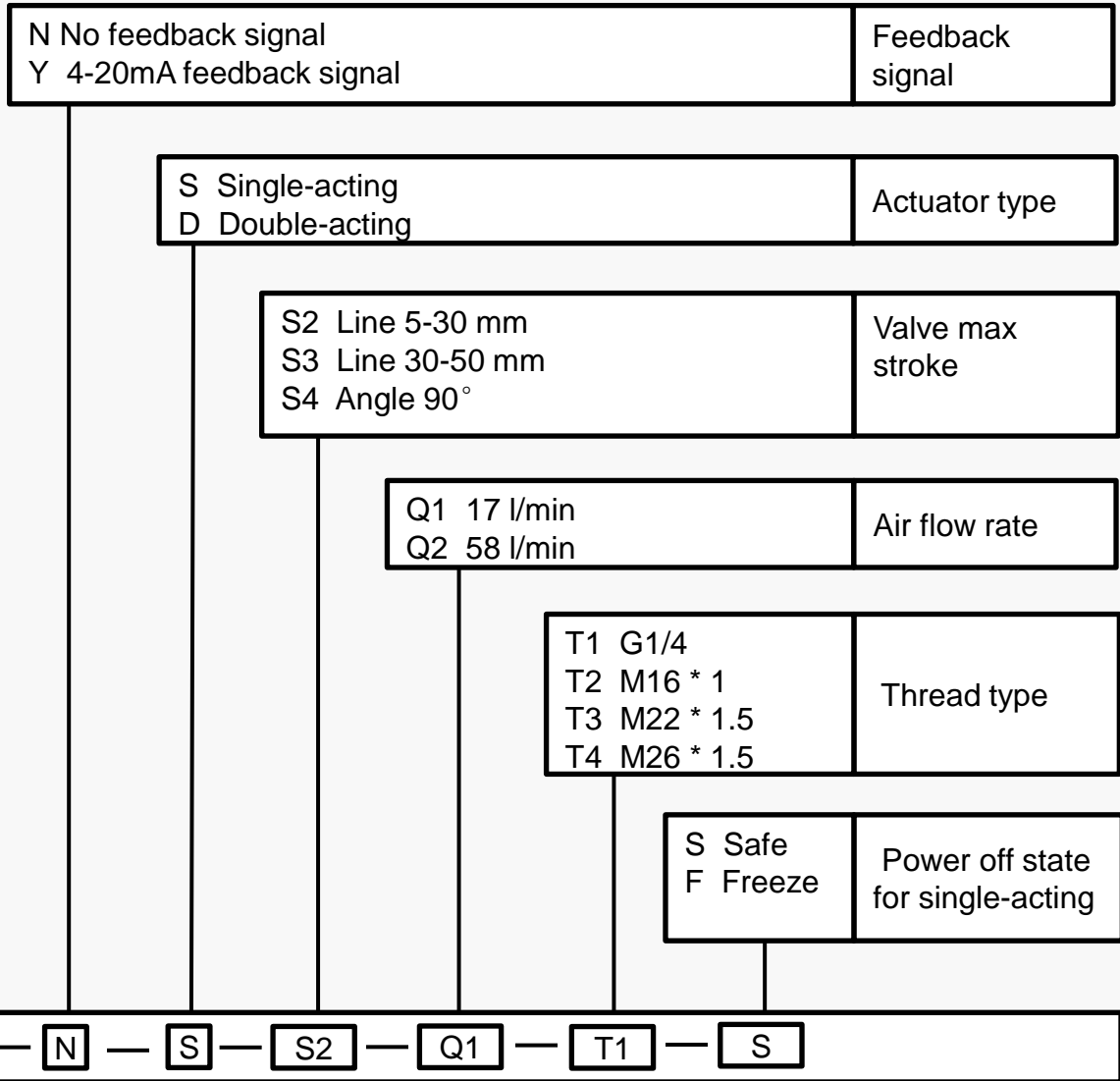

## Remark:

In the **air flow rate** option, code Q1 is suggested to match the actuator of 40-100 mm internal gas chamber diameter, code Q2 is suggested to match the actuator of 125-160 mm internal gas chamber diameter. code Q2 is only used for single-acting actuator. The air flow rates for code Q1 and Q2 are under the condition of 0.6Mpa input pressure.

In the **valve max stroke** option, AT actuator range for code S4 is AT50~AT125. For other actuator models, please consult our company. It is no need to select the **thread type** option for code S4.

**Power off state for single-acting** option is **Safe** by default.

## Signal flow diagram

---

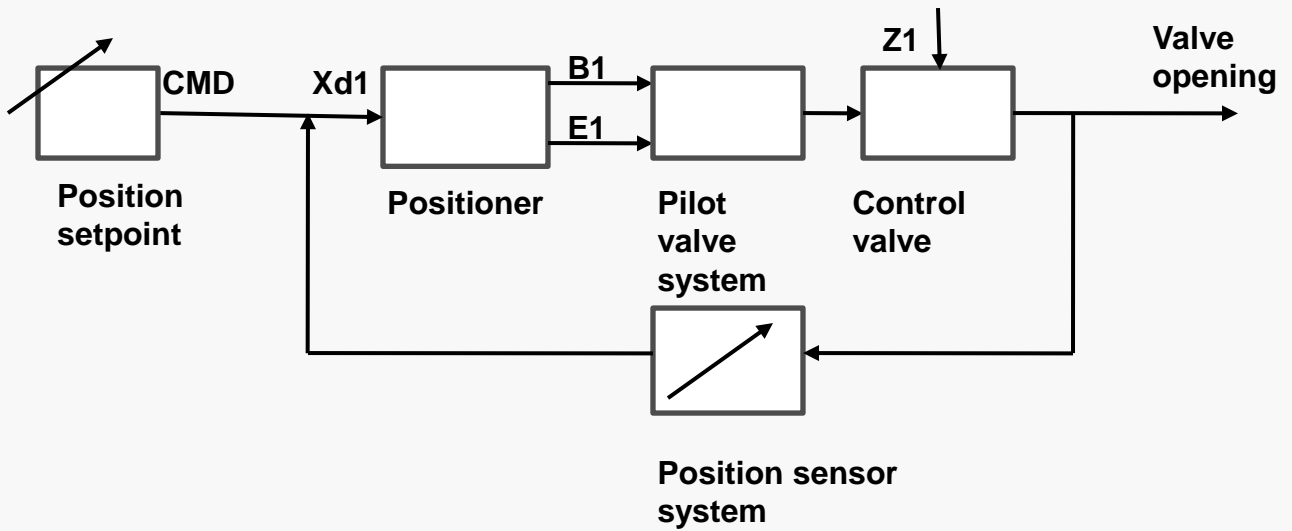

## Schematic diagram

---

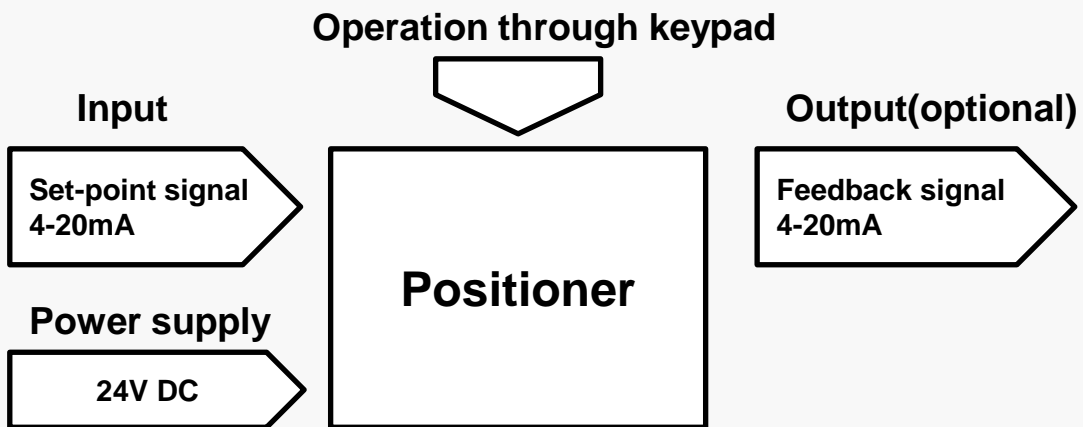





















## Function comparison for all types

FUNCTION	1600	1601	1500
Explosion-proof	√	√	×
Process control	×	√	×
4-20mA signal input	√	√	√
4-20mA signal output	√	√	○
Autotune	√	√	√
Valve position manual adjustment	√	√	√
Sealing function	√	√	√
Dead band setting	√	√	√
4-20mA input signal error detection	√	√	√
Factory setting	√	√	√
Characteristic curve setting	√	√	×
Direction of set-point value	√	×	×
Valve stroke range limiting	√	√	×
Safety position setting	√	√	×
Binary signal input/output	√	√	×
Input signal calibration	√	√	×
Speed setting of manual adjustment	√	√	×
Code protection	√	√	×

√	YES
×	NO
○	optional



# Valve match

	Intelligent valve positioner 1600 series	Intelligent valve positioner 1500 series	Intelligent valve positioner IP4000 series
Diaphragm valve 2800 series			
T type angle seat valve (3rd party company)			
Pneumatic sleeve valve (3rd party company)			
Pneumatic butterfly valve with rotary actuator (3rd party company)			
Pneumatic ball valve with rotary actuator (3rd party company)			
Angle seat Valve 2710 series			N/A
Divert seat valve (3rd party company)			N/A
Pneumatic butterfly valve with linear actuator (3rd party company)			N/A

# 1500系列智能电气阀门定位器



- 电气防水接头
- LED状态显示
- 快速简易启动

## 技术参数

材料	聚碳酸脂 ( PC ) 硅橡胶(SI) 聚酰胺(PA6-GF30 )
电源	直流 24V ±10%
信号输入	4 – 20 mA
设定信号输入阻抗	120Ω
压缩空气要求 颗粒度要求 颗粒密度要求 凝点要求 油脂浓度要求	中性气体, 符合 DIN ISO 8573-1 要求 Class 5 (<40μm particle size) Class 5 (<10mg/m <sup>3</sup> ) Class 3 (<-20°C) Class 5 (<25mg/m <sup>3</sup> )
环境温度	0-70°C
气动接头	1/4英寸插入式软管接头(内径Φ 6mm)
电气快速接头	M12 三针 B标准(电缆直径ø 4-6mm) M12 四针 D标准(电缆直径ø 4-6mm)
气源压力	3-7 bar , 具体值视执行机构而定
输出气体流量	17 l/min(输入压力为0.6Mpa) 58 l/min(输入压力为0.6Mpa, 仅单作 用)
阀门行程控制范围	直行程5-50 mm 角行程90°
安装方式	倾向于安装在执行器顶端, 通过螺纹 和执行器连接
防护等级	IP66
功耗	<5W

1500系列智能电气阀门定位器是专为一体式气动调节阀所设计的, 特别适用于角座阀和隔膜阀产品。

该产品操作简便, 可轻松通过按键面板进行操作。

定位器可通过检测位移传感器信号, 对阀位进行快速精确调节。

## 组合方式



隔膜式调节阀



角座式调节阀

## 产品结构

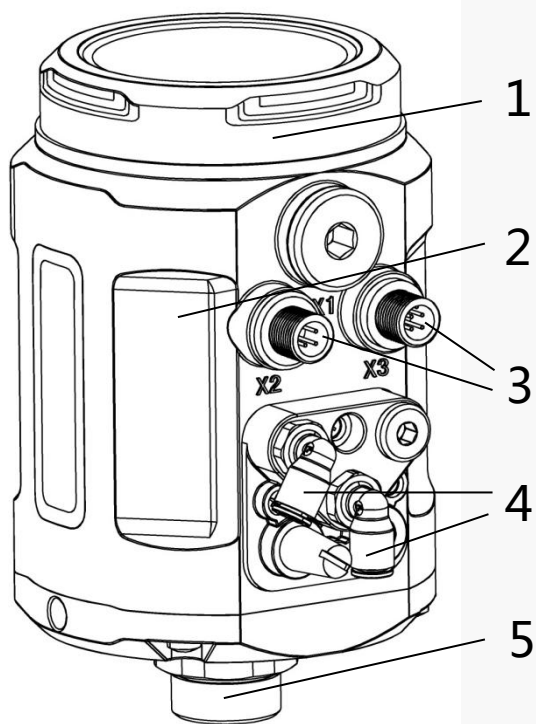

1. 防护盖
2. 主壳体
3. 电气接口
4. 气动接口
5. 执行器连接件

# 机械尺寸

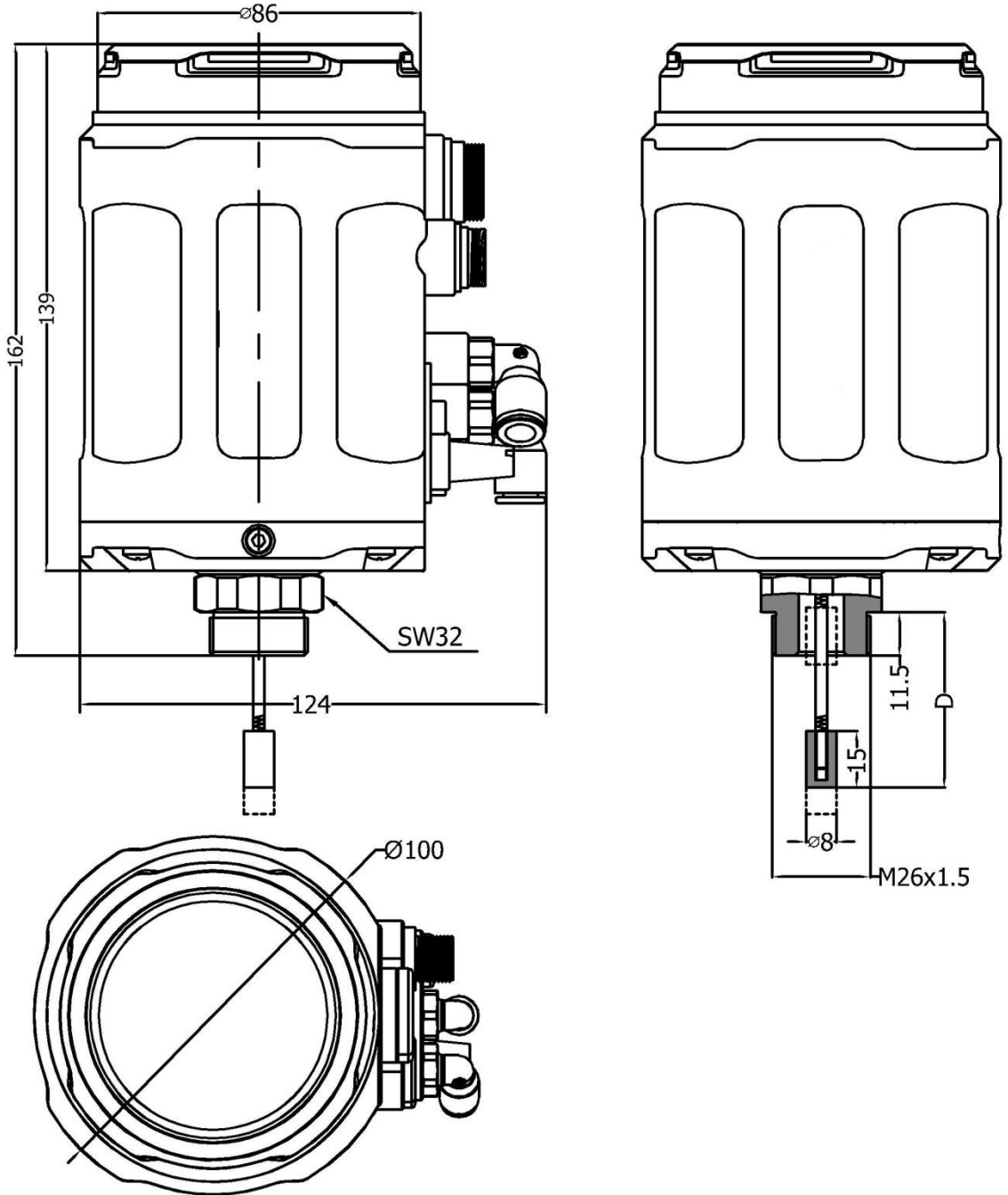

## 操作界面角度调整

将定位器与阀门连接之后，定位器可与阀门之间做角度调整。若需要调整定位器操作界面角度，松开A处的内六角紧定螺钉后，顺时针或逆时针180°范围内调整到需要的角度，再拧紧紧定螺钉。

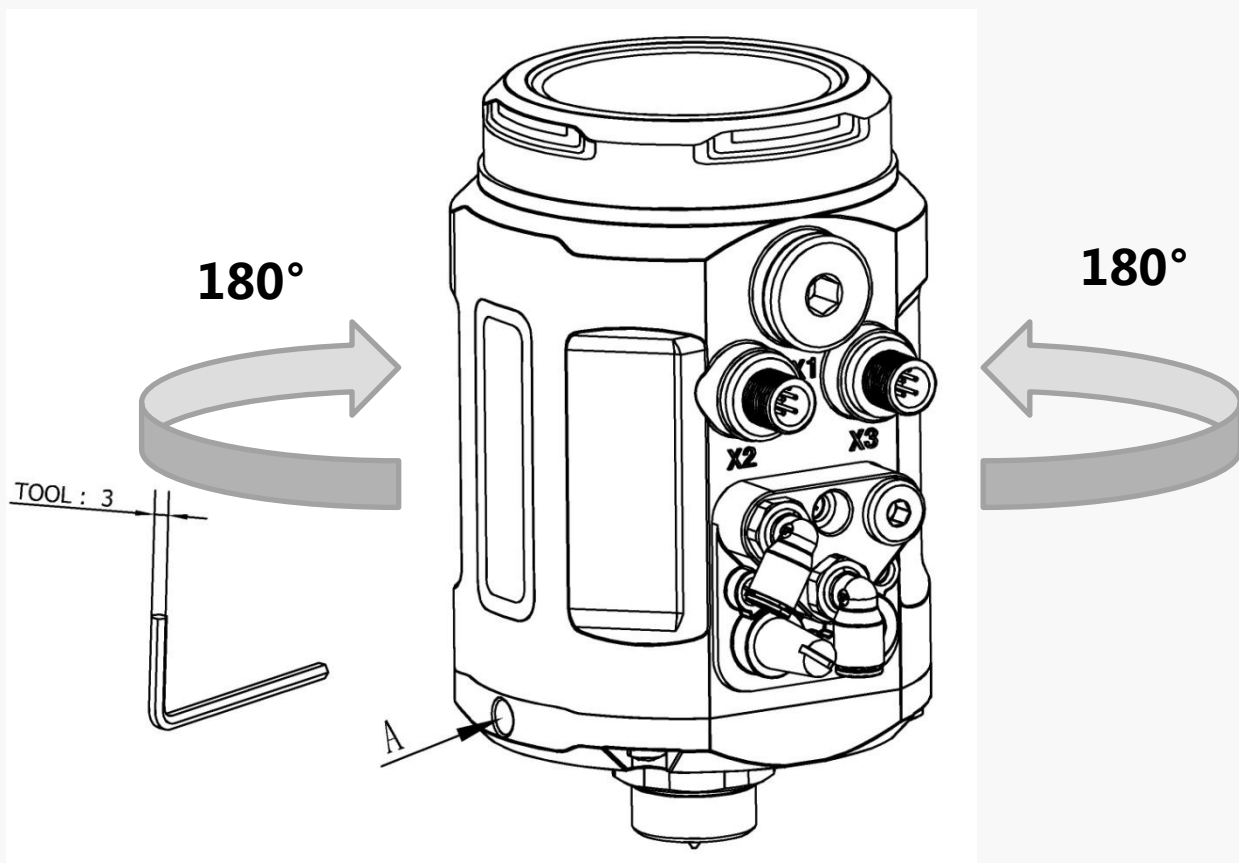

## 电气接口

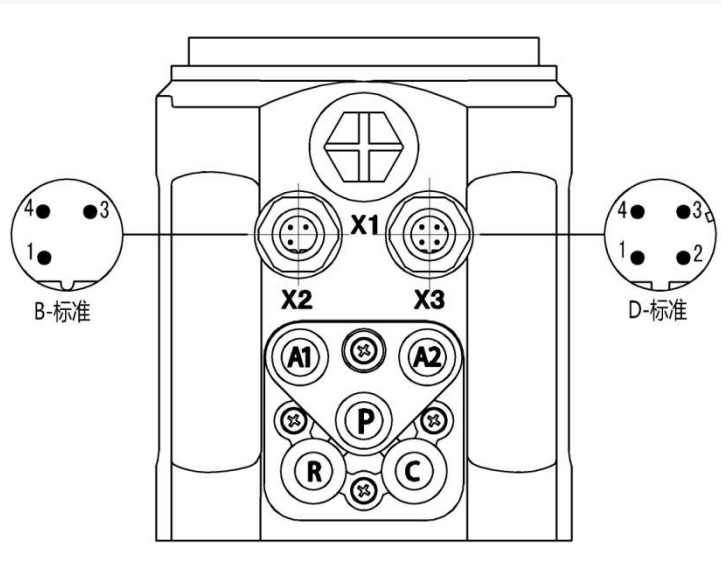

### X2 (可选)

端子号	描述	信号类型
1	模拟信号输出 +	4 – 20 mA
3	模拟信号输出 GND	GND
4	空	无

### X3

端子号	描述	信号类型
1	电源 +	+24 V
2	电源GND	GND
3	设定信号输入 +	4 – 20 mA
4	设定信号输入GND	GND

## 气动接口

P	气源进入 (内置滤网, 过滤尺寸5 $\mu$ m)
R	排气
C	单向阀
A1	先导气口1
A2	先导气口2

## 产品选型

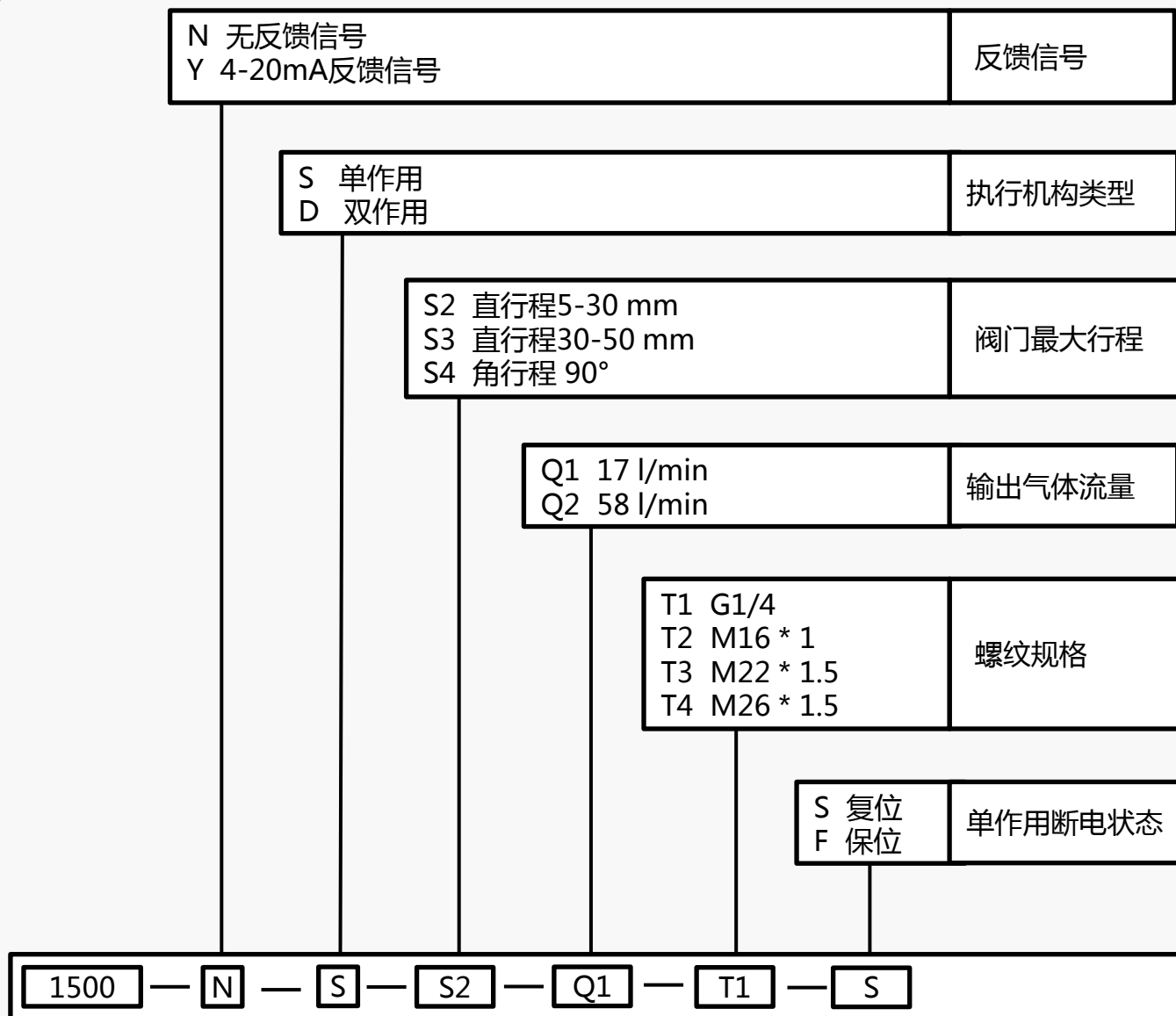

备注：

**输出气体流量**选项中，代码Q1建议匹配气室内径40-100 mm 的执行器，代码Q2建议匹配气室内径 125-160 mm的执行器。代码Q2仅适用于单作用执行器。代码Q1,Q2标注的气体流量均为输入压力在0.6Mpa下的气体流量。

**阀门最大行程**选项中代码S4适用的AT执行器范围是AT50~AT125。其他型号请咨询我司。如果选择代码S4，则**螺纹规格**选项不需要选择。

**单作用断电状态**默认为**复位**。

## 信号流程示意图

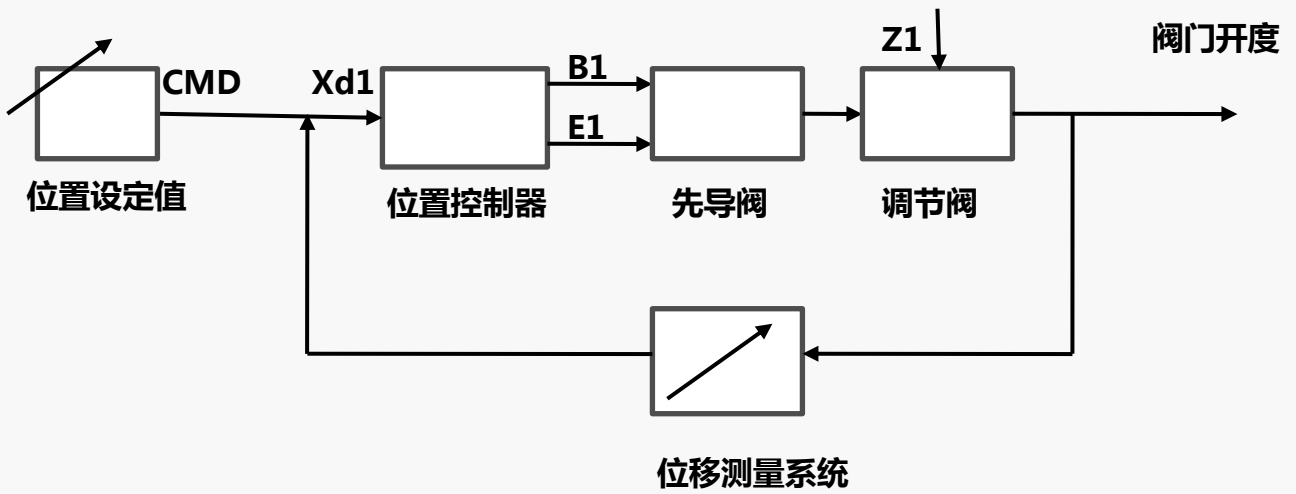

## 原理图

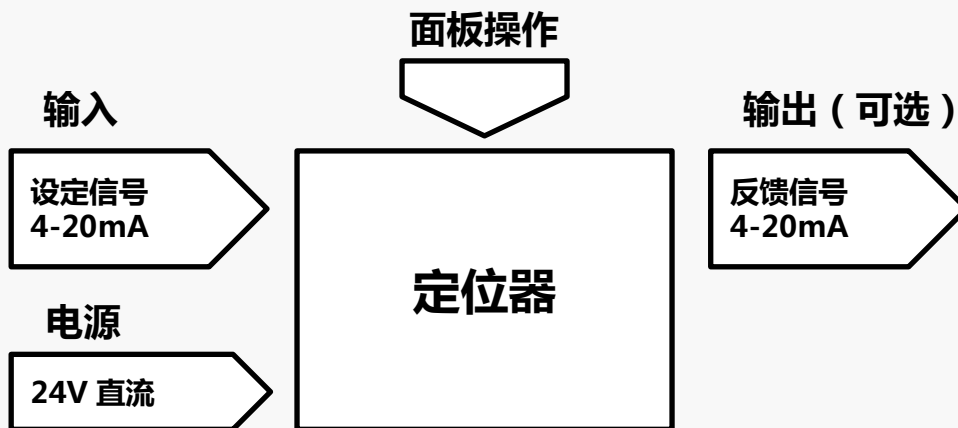



## 各型号功能对比

功能	1600	1601	1500
防爆	√	√	×
过程控制	×	√	×
4-20mA信号输入	√	√	√
4-20mA信号输出	√	√	○
自整定	√	√	√
手动调节阀位	√	√	√
紧闭功能	√	√	√
死区设置	√	√	√
4-20mA输入信号错误检测	√	√	√
恢复出厂设置	√	√	√
特性曲线设置	√	√	×
信号方向设置	√	×	×
行程限制	√	√	×
安全位置设置	√	√	×
开关量信号输入/输出	√	√	×
输入信号校正	√	√	×
手动调节速度设置	√	√	×
密码保护	√	√	×

√	有该功能
×	无该功能
○	可选

	智能阀门定位器 1600系列	智能阀门定位器 1500系列	智能阀门定位器 IP4000系列
隔膜阀2800系列			
T型气动截止阀 (第三方)			
气动单座薄膜式调节阀 (第三方)			
角行程气动蝶阀 (第三方)			
角行程气动球阀 (第三方)			
调节式角座阀 2710系列			N/A
换向阀 (第三方)			N/A
直行程气动蝶阀 (第三方)			N/A